

# Copper Water Cylinders

Suitable for Solar

maxi  
pod

by  
copper  
ind

Manufacturers of Domestic and  
Industrial Hot Water Cylinders.

For more information on the  
MaxiPod and any of our other  
products, please contact us on  
our details below.

Copper Industries (Ireland) Ltd.  
Toome Business Park,  
21 Hillhead Road,  
Toome, Co. Antrim,  
BT41 3SF.

From N.Ireland  
Tel: 028 7965 9736  
Fax: 028 7965 0000

From ROI  
Tel: 048 796 59736  
Fax: 048 796 50000

Email: [info@copperindustries.co.uk](mailto:info@copperindustries.co.uk)  
Web: [www.copperindustries.co.uk](http://www.copperindustries.co.uk)



# Energy Store Hot Water Cylinder

Instruction Manual

PLEASE LEAVE WITH HOUSEHOLDER

maxi  
pod

# \_1 Maintenance Undertaken

Please Fill In when any work is undertaken on the unit.

MaxiPod Maintenance:

Date:

Company/Specialist:

Comments:

Date:

Company/Specialist:

Comments:

Date:

Company/Specialist:

Comments:

Date:

Company/Specialist:

Comments:

Date:

Company/Specialist:

Comments:

# \_2 Important Installation Advice

1. The installation of your MaxiPod Energy Store hot water system should only be undertaken by a competent person.
2. The unit should be handled with care to ensure that the unit and particularly the blending matrix remain undamaged. DO NOT carry or lift by the external pipework assembly.
3. The unit should be installed on a level base capable of withstanding the weight of the unit when filled.

As a guide the filled weights of our standard units are as follows :-

### CYLINDER:

140 litres	-	175 kgs
180 litres	-	215 kgs
210 litres	-	250 kgs
250 litres	-	290 kgs

### COMBINATION TANK:

140 litres	-	180 kgs
180 litres	-	225 kgs
210 litres	-	255 kgs
250 litres	-	300 kgs

4. Sufficient space should be available to make and maintain the plumbing connections and blending matrix and service the ball valve ( combination tank ) and install / replace the immersion heaters. Incoming cold water as it is passing through the heat store. Excessive flow rates will diminish the heat exchange performance. Reduce flow rates to achieve optimum performance.

### INSUFFICIENT PRESSURE

- (a) Incoming cold water mains pressure inadequate. **Refer to water authority.**
- (b) Incoming cold water mains pressure reducing valve set incorrectly or malfunctioning. **Check setting and adjust as appropriate.**
- (c) In line filters / strainer blocked. **Clean out!**

## \_3 Trouble – shooting

Whilst the **MaxiPod Energy Store** is essentially trouble free, problems may occasionally arise. To assist in their resolution we offer a checklist of problems and their causes.

### PROBLEM

**Lack of hot water.**

### POSSIBLE CAUSE

- (a) **Immersion heater(s) not working.**
- (b) **Immersion heater thermostats not working or incorrectly set.** Our immersion heaters are preset at 65°C which in normal circumstances should be adequate. However, if large volumes of hot water are required over a long period you may wish to consider resetting the thermostats higher ( but to no more than 75°C). Similarly, independent thermostats affixed to the unit to control boiler input may also be reset higher to improve performance.
- (c) **Flow rate too high.**  
In spite of the high efficiency of the finned coil heat exchanger a certain amount of time is needed to heat up the water.
  - 1. Incoming mains pressure should not exceed 3.5 bar. It is recommended that all installations include a pressure reducing valve on the incoming cold mains set to a maximum of 3.5 bar. Pressure reducing valves are available as an option from the Copper Industries (Ire). Ltd.
  - 2. Avoid excessive use of flux as this can damage the unit and particularly the valves. Ensure the system is thoroughly flushed of any debris or flux before final fill.
  - 3. The introduction of an approved system additive is highly recommended.

## \_4 Maintenance

The **MaxiPod Energy Store** is relatively maintenance free. We do strongly recommend, however, that the thermostatic mixing valve be serviced every three or four months to avoid in particular the potential build-up of limescale detrimental to its operation.

For similar reason the inline filters/strainer should be cleaned out on a regular basis.

In hard water areas we recommend that some form of anti-scaling device be fitted. Please note that some water softening devices may reduce the pressure of the incoming cold water.

## \_5 Installation Details

---

**Installer Details:**

---

---

Date of Installation:

---

---

Name:

---

---

Address:

---

---

---

---

---

Telephone:

---

---

Comments:

---

---

---

---

---

## \_6 Introduction

Your **MaxiPod Energy Store** thermalstore domestic hot water supply system offers you a highly efficient and effective means of providing a pressure hot service direct from your mains cold water supply.

Water from the mains cold supply is admitted to the cylinder via a high efficiency 'finned' copper coil heat exchanger that gathers the accumulated heat in the 'store'. This, now hot, mains pressure water is then passed through a thermostatic mixing valve ('B' on the schematic drawing) where it is blended with cold water to your desired temperature.

The heating of the 'store' of water can be achieved in a variety of ways either singly or in combination:

### DIRECT

- (a) By way of immersion heaters normally using the Economy 7 tariff or similar.
- (b) Using hot water circulating from a boiler through your central heating system.

### INDIRECT

- (a) By exchanging the heat from the hot water circulating from a boiler through your central heating system via a copper coil heat exchanger.

To assist in the maintenance of the temperature of the Energy Store and minimise heat loss, the unit is provided with an extra-thick layer of factory applied foam insulation to a specification in excess of the requirements of 'Part L' of the Building Regulations.

## \_7 Energy Store Connections (Cylinder)

### DIAGRAM KEY

- A. Cold mains in (reduced to 3.5 bar pressure)
- B. Mixer hot water out via thermal mixing valve
- C. Immersion heater (Fitted) (3 Kw - 285mm long)
- D. Drain connection
- E. Control thermostat connection indirect only
- F. Direct boiler connection (if applicable)
- G. To space heating (direct only if applicable)
- G. To space heating
- I. Store vent connection
- J. Duel thermostat (Fitted)
- K. Temp gauge (Fitted)

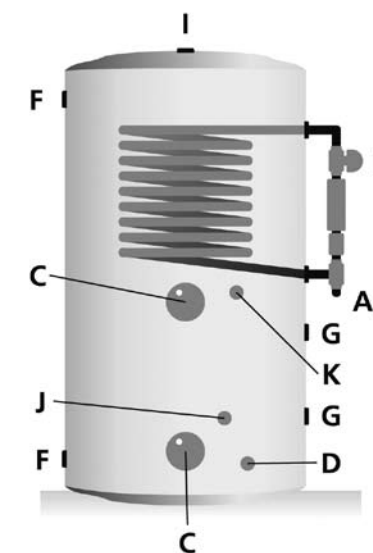
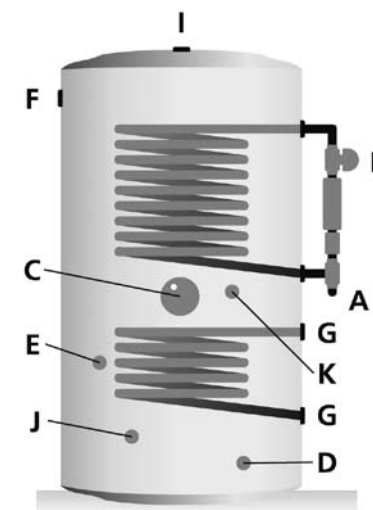

\_8

# Energy Store Connections (Combination)

## DIAGRAM KEY

- A. Cold mains in (reduced to 3.5 bar pressure)
- B. Mixer hot water out via thermal mixing valve
- C. Immersion heater (Fitted) (3 Kw - 285mm long)
- D. Drain connection
- E. Control thermostat connection (indirect only)
- F. Direct boiler connection (if applicable)
- G. To space heating (direct only if applicable)
- G. To space heating (indirect only)
- H. Dual thermostat (Fitted)
- I. Temp guage (Fitted)

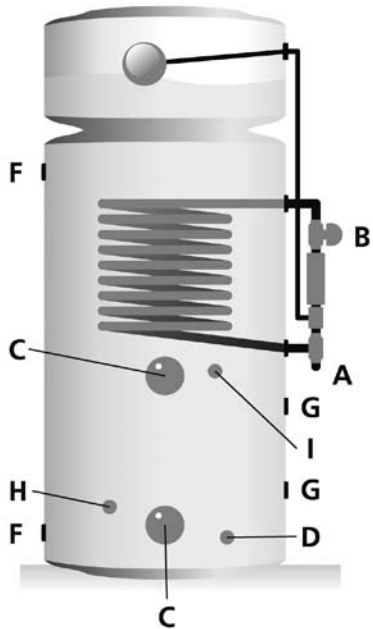
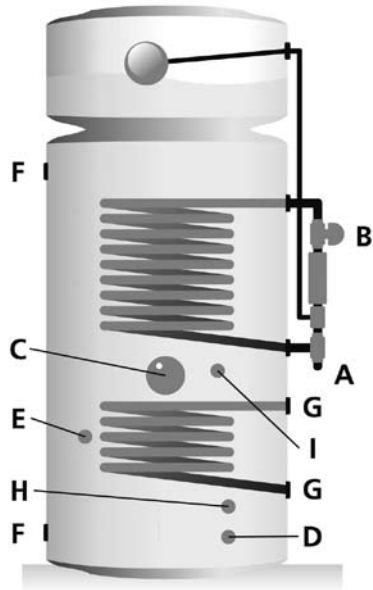

—